

DC-MOTOREN MIT PLANETENGETRIEBE



Ø 42 mm



24 V/DC



8,5 - 980 min⁻¹



1,1 - 12 Nm

Allgemeines

Alle Angaben zu DC-Motoren und DC-Linearantrieben sind Mittelwerte gemessen im kalten Zustand. Abweichungen von $\pm 10\%$ sind möglich. Technische Änderungen vorbehalten.

Aktuelle Informationen finden Sie auf unserer Internetseite unter www.seefrid.com.

General

all data to DC motors and DC linear actuators are measured average values at cold engine. Deviations from $\pm 10\%$ are possible. Subject to change without notice.

Actually information you will find on our website www.seefrid.com.

Symbole / Symbols

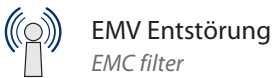
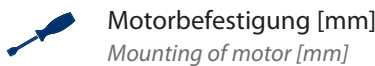
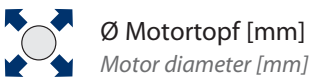
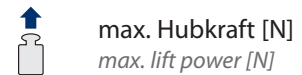
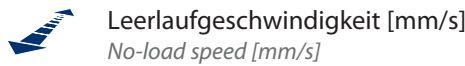
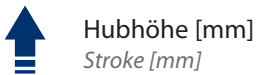
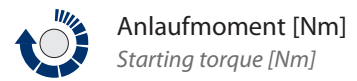
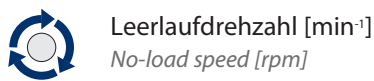
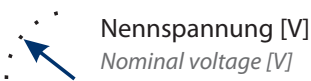

Allgemeines Hall-Sensor Anschlussschema / General hall-sensor connection diagram

- **Anschlussschema mit Einkanal-Hall-Sensor**
Connection diagram with a one channel hall-sensor

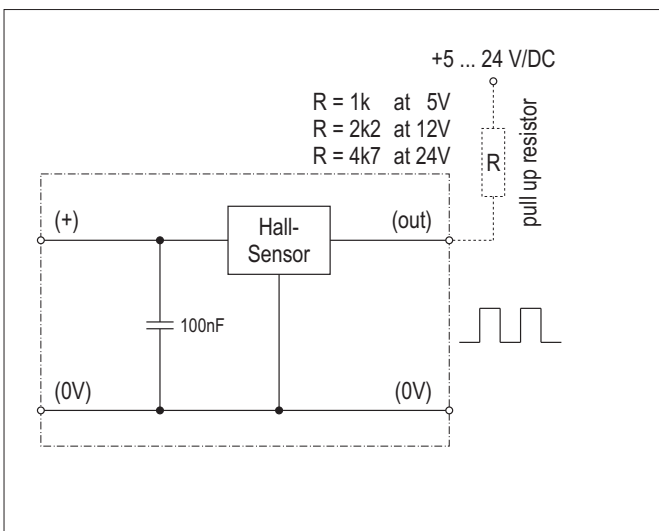

- **Anschlussschema mit Zweikanal-Hall-Sensor**
Connection diagram with a two channel hall-sensor

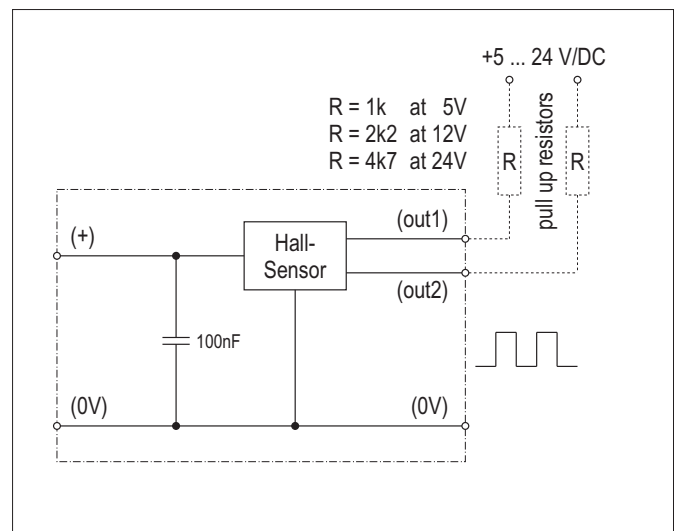

Umrechnungen (für die Praxis gerundete Werte) / *Conversion (rounded values)*

• **Kräfte** / *Forces*

1 N = 0,1 kg = 100 g 1 kg = 10 N = 10.000 mN

• **Drehmomente** / *Torques*

1 Nm = 10.000 g/cm = 10 kg/cm 1 kg/cm = 0,1 Nm = 10 Ncm
 1 Ncm = 100 g/cm = 0,1 kg/cm 1 g/cm = 1·10⁻⁴ Nm = 1·10⁻² Ncm

Kennlinie / *Diagram*

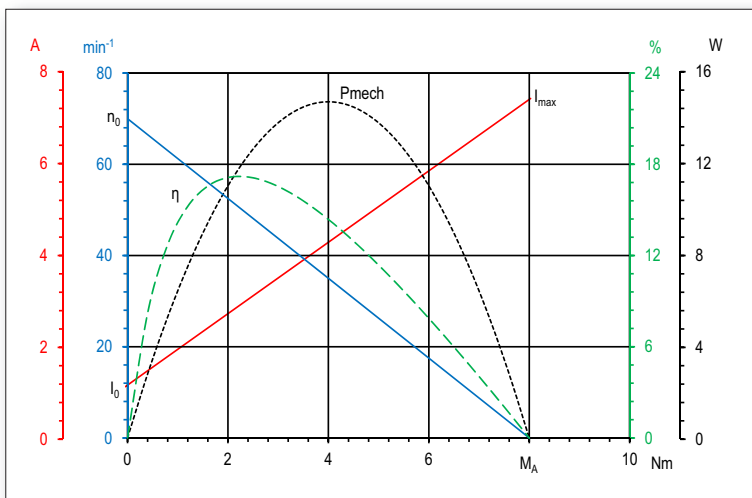

Legende / *Description*

- n_0 = Leerlaufdrehzahl / *No load speed* [min⁻¹]
- η = Wirkungsgrad / *Efficiency* [%]
- P_{mech} = mech. Leistung / *Mech. power* [W]
- I_0 = Leerlaufstrom / *No load current* [A]
- I_{max} = Maximalstrom / *Max. current* [A]
- M = Drehmoment / *Torque* [Nm]
- M_A = Anlaufmoment / *Max. torque* [Nm]

EMV-Entstörung / *EMC filter*

Ein Teil unserer DC-Motoren und DC-Linearantriebe sind mit Entstörkomponenten ausgestattet. Hierbei handelt es sich ausschließlich um eine Grundentstörung. Die tatsächlich notwendige Entstörung ist anwendungsabhängig zu ermitteln.

Some of our DC motors and DC linear actuators have built-in EMC filter components. This is only a basic interference suppression. The really needed interference suppression must be determined in addition to the complete machine.

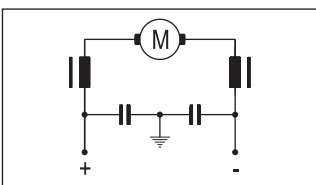

Kapazitive und induktive EMV-Entstörung. *EMC suppression with capacitor and choke.*

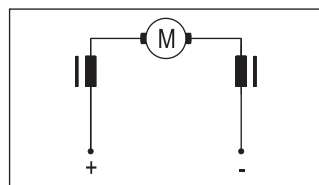

Induktive EMV-Entstörung. *EMC suppression with choke.*

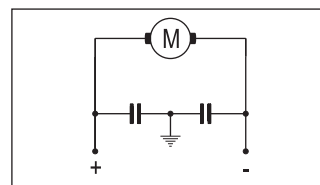

Kapazitive EMV-Entstörung. *EMC suppression with capacitor.*

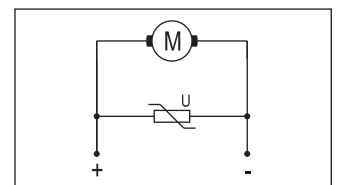

EMV-Entstörung mit einem Varistor. *EMC suppression with a varistor.*

Beispiel: / *Example:*



1,0 nF
4,7 μH

Beispiel: / *Example:*



- nF
4,7 μH

Beispiel: / *Example:*



1,0 nF
- μH

Beispiel: / *Example:*



Varistor



Ø 42 mm



12/24 V/DC



8,5 - 980
min⁻¹



1,1 - 12 Nm



10 nF
- µH



optional

COUNTER CLOCKWISE
with positive voltage on positive terminal

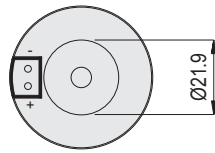
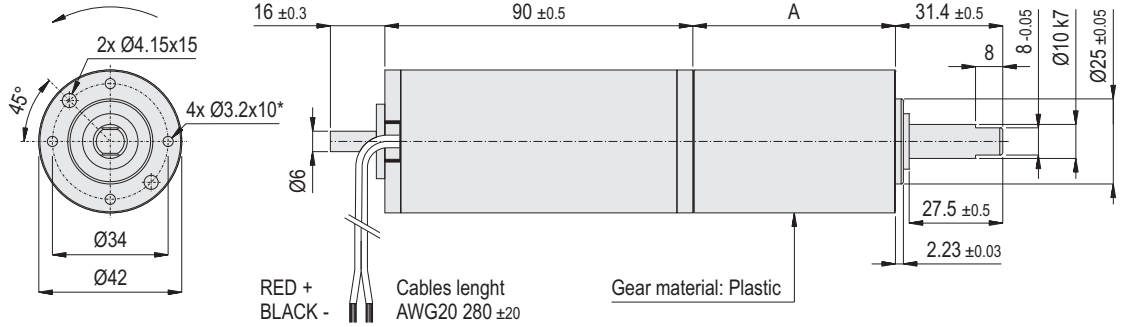

***HINWEIS / Remark**

Empfohlene Schraube EJOT Delta PT WN 5452 40 x ..., T_{max} = 1,6 +0,2 Nm. Einschraubtiefe von 10 mm einhalten!

Recommended screw EJOT Delta PT WN 5452 40 x ..., T_{max} = 1,6 +0,2 Nm. Observe reach of screw of 10 mm!

Kennlinie - Motor ohne Getriebe

Graph - Motor without gear

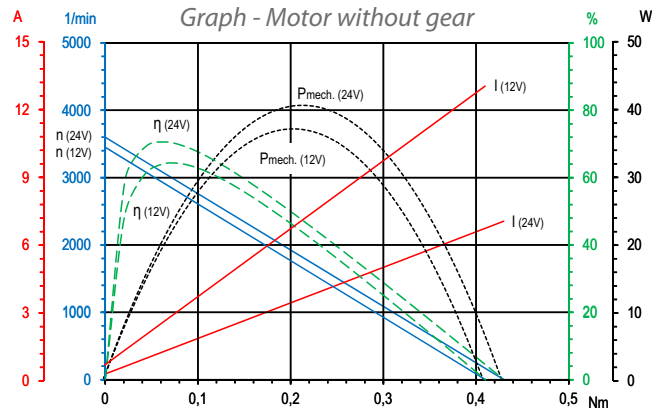

Technische Daten / Technical data

Schutzart IP 40 / Protection class IP 40

Bestell-Nr. Order-No.	Nennspannung Nominal voltage	Leerlaufdrehzahl No-load speed	Anlaufmoment Starting torque	Nennmoment Nominal torque	Stufe/n Stage/s	Übersetzung Gear ratio	Mass A Dim. A
514.422 504.422	12 24 V/DC	8,5 min ⁻¹	10,0 Nm	5,0 Nm	■ ■ ■	422:1	75,3 mm
514.300 504.300	12 24 V/DC	12,0 min ⁻¹	12,0 Nm	6,0 Nm	■ ■ ■	300:1	75,3 mm
514.213 504.213	12 24 V/DC	16,5 min ⁻¹	12,0 Nm	6,0 Nm	■ ■ ■	213:1	75,3 mm
514.152 504.152	12 24 V/DC	23 min ⁻¹	12,0 Nm	6,0 Nm	■ ■ ■	152:1	75,3 mm
514.121 504.121	12 24 V/DC	29 min ⁻¹	12,0 Nm	6,0 Nm	■ ■ ■	121:1	75,3 mm
514.096 504.096	12 24 V/DC	37 min ⁻¹	12,0 Nm	6,0 Nm	■ ■ ■	96:1	75,3 mm
514.056 504.056	12 24 V/DC	63 min ⁻¹	10,0 Nm	4,0 Nm	■ ■	56:1	59,3 mm
514.040 504.040	12 24 V/DC	87 min ⁻¹	11,5 Nm	2,9 Nm	■ ■	40:1	59,3 mm
514.028 504.028	12 24 V/DC	127 min ⁻¹	8,0 Nm	2,0 Nm	■ ■	28:1	59,3 mm
514.023 504.023	12 24 V/DC	154 min ⁻¹	6,0 Nm	1,6 Nm	■ ■	23:1	59,3 mm
514.018 504.018	12 24 V/DC	197 min ⁻¹	5,1 Nm	1,3 Nm	■ ■	18:1	59,3 mm
514.013 504.013	12 24 V/DC	273 min ⁻¹	3,7 Nm	0,9 Nm	■ ■	13:1	59,3 mm
514.007 504.007	12 24 V/DC	470 min ⁻¹	2,3 Nm	0,6 Nm	■	7,5:1	43,5 mm
514.005 504.005	12 24 V/DC	670 min ⁻¹	1,6 Nm	0,4 Nm	■	5,3:1	43,5 mm
514.004 504.004	12 24 V/DC	770 min ⁻¹	1,3 Nm	0,3 Nm	■	4,3:1	43,5 mm
514.003 504.003	12 24 V/DC	980 min ⁻¹	1,1 Nm	0,3 Nm	■	3,6:1	43,5 mm

Neuheiten 2014

Diese Angaben sind Mittelwerte gemessen im kalten Zustand des Motors. Abweichungen von ±10% sind möglich. Technische Änderungen vorbehalten.
These data are measured average values at cold engine. Deviations from ±10% are possible. Subject to change without notice.

