

COUNTER CLOCKWISE
with positive voltage on red cable

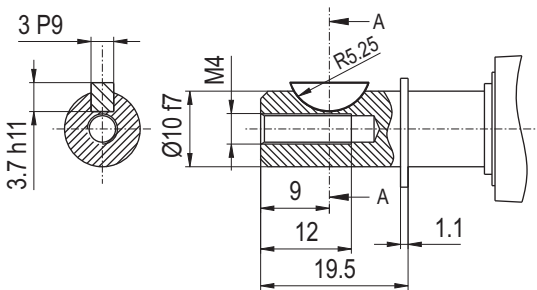

HINWEIS / Remark

Lieferung inkl. Scheibenfeder. Supply incl. halfmoon-key.

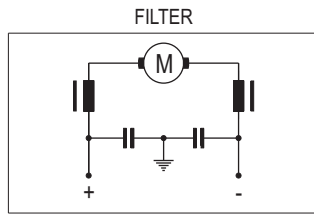
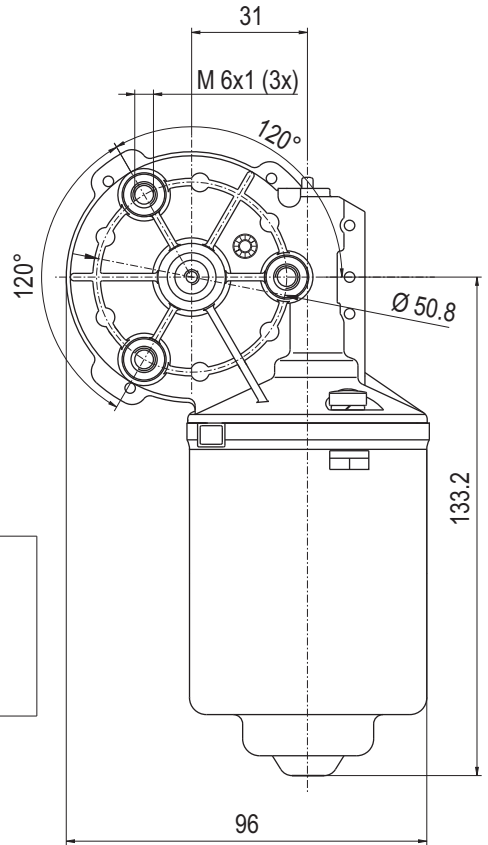
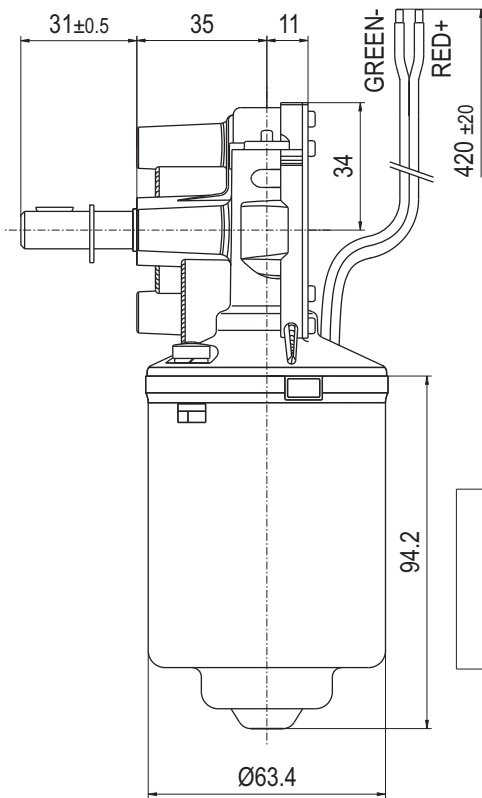
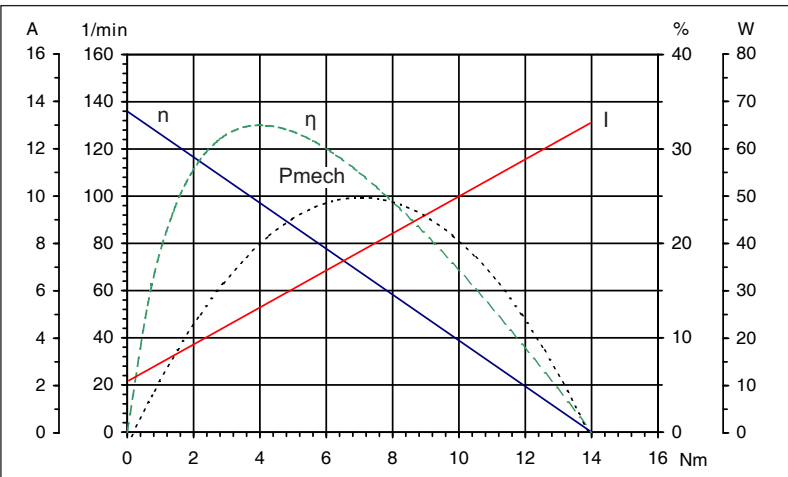

Technische Daten / Technical data		
Nennspannung / Nominal voltage	24	V/DC
Leerlaufdrehzahl / No-load speed	136	min ⁻¹
Nennmoment / Nom. torque	2	Nm
Anlaufmoment / Starting torque	14	Nm
Zahnradwerkstoff / Gear material	Kunststoff / Plastic	
Übersetzung / Gear ratio	53:2	
Schutzart / Protection class	IP 30	
Gewicht / Weight	1,2	kg

Diese Angaben sind Mittelwerte gemessen im kalten Zustand des Motors. Abweichungen von ±10% sind möglich. Technische Änderungen vorbehalten.
These data are measured average values at cold engine. Deviations from ±10% are possible. Subject to change without notice.