

COUNTER CLOCKWISE  
with positive voltage on red cable

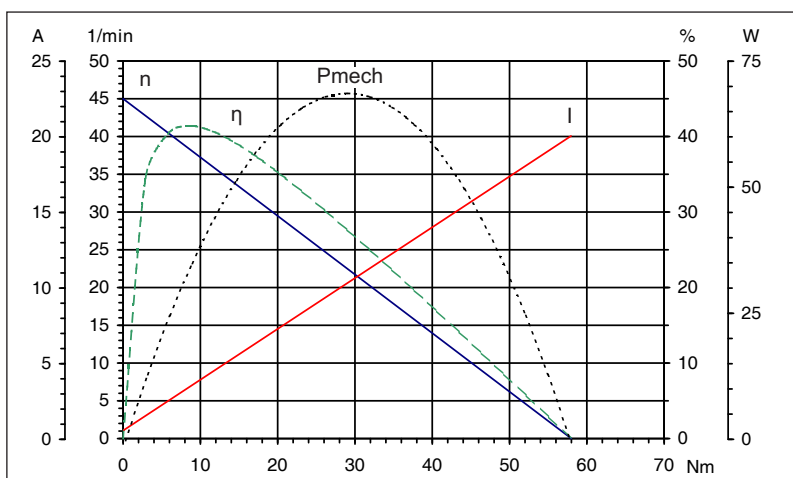
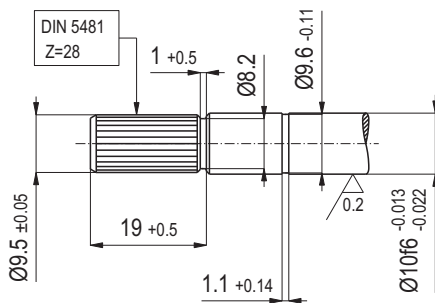
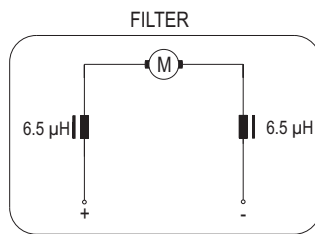
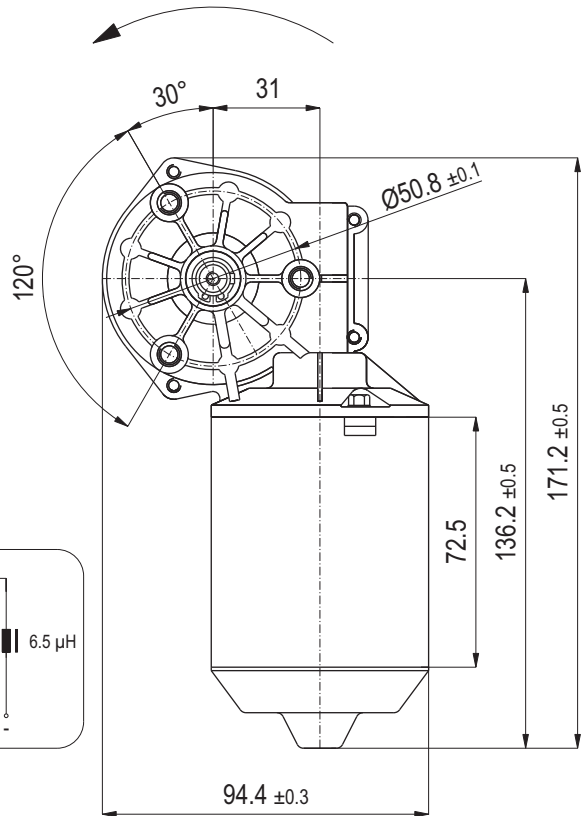

Technische Daten / Technical data		
Nennspannung / Nominal voltage	24	V/DC
Leerlaufdrehzahl / No-load speed	45	min <sup>-1</sup>
Nennmoment / Nom. torque	8	Nm
Anlaufmoment / Starting torque	58	Nm
Zahnradwerkstoff / Gear material	Kunststoff / Plastic	
Übersetzung / Gear ratio	69:1	
Schutzart / Protection class	IP 30	
Gewicht / Weight	1,1	kg

HK 2010

Diese Angaben sind Mittelwerte gemessen im kalten Zustand des Motors. Abweichungen von  $\pm 10\%$  sind möglich. Technische Änderungen vorbehalten.  
These data are measured average values at cold engine. Deviations from  $\pm 10\%$  are possible. Subject to change without notice.