

# Series GML

## Motor type 404 536

Design Data	
Commutation	Brushed
Direction of rotation	Bi-directional
Bearing type	A:Ball - B:Sleeve

Performance data		
Rated voltage [V]	$U_N$	24
Nominal torque [Nm]	$M_N$	0.30
No-load speed [ $\text{min}^{-1}$ ]	$n_0$	4,000.0
Nominal power [W]	$P_N$	107
Nominal current [A]	$I_N$	7.5
Nominal force [kN]	$F_N$	0.00
Duty cycle		s1

Sensor data	
Pulses	0
Output channels	0

Other data	
Gear ratio	
Gear wheel material	
Suppression components	5 $\mu$ H, 10nF
Enclosure class	IP 30
Weight [kg]	1.150

Remarks:

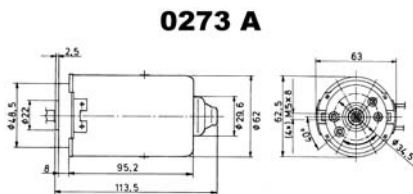

### Motor picture

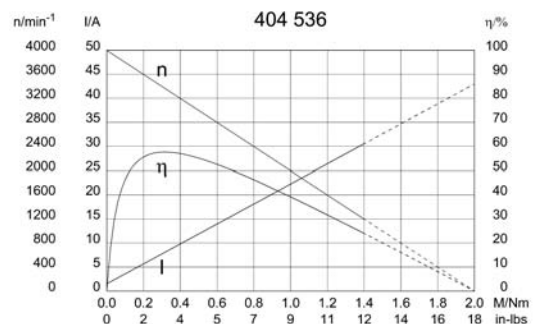

### Output shaft drawing (W), Wiring diagrams (S) and Connector layout (K)

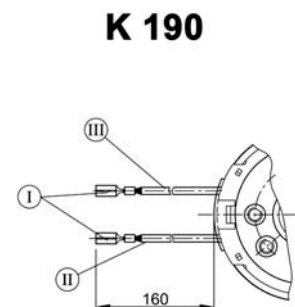
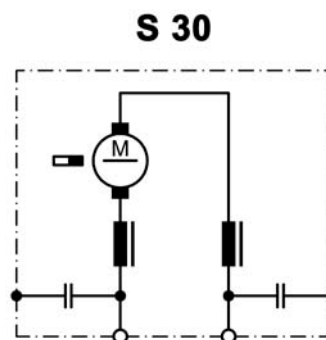
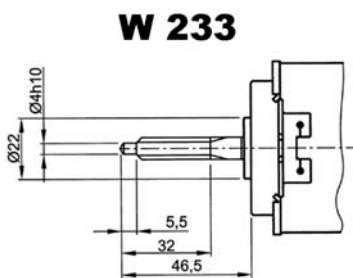

no of starts 2, lead angle 19°48'54", pressure angle 15°, module 1, pitch 3,141 mm (0,124")

I Receptacles for tabs 2,8 x 0,8 DIN 46 247  
 II black  
 III red